

Ersatzteilliste

ALLESMÄHER

HERKULES

FL500A

FL500B

FL500BC

FL500BC (2-Hand Messerzuschaltung)

MODEL	CODE NO.
FL500A	80-1035-???-00
FL500B	0214-??????

CONTENTS

Fig.1	HANDLE & ROTARY COVER-----	1
Fig.2	TRANSMISSION CASE-----	5
Fig.3	FRAME-----	9
Fig.4	WHEEL-----	17

OREC CO.,LTD. / HERKULES MOTORGERÄTE

Update : Ab Mai 2003

FIG.1 HANDLE & ROTARY COVER

-1-

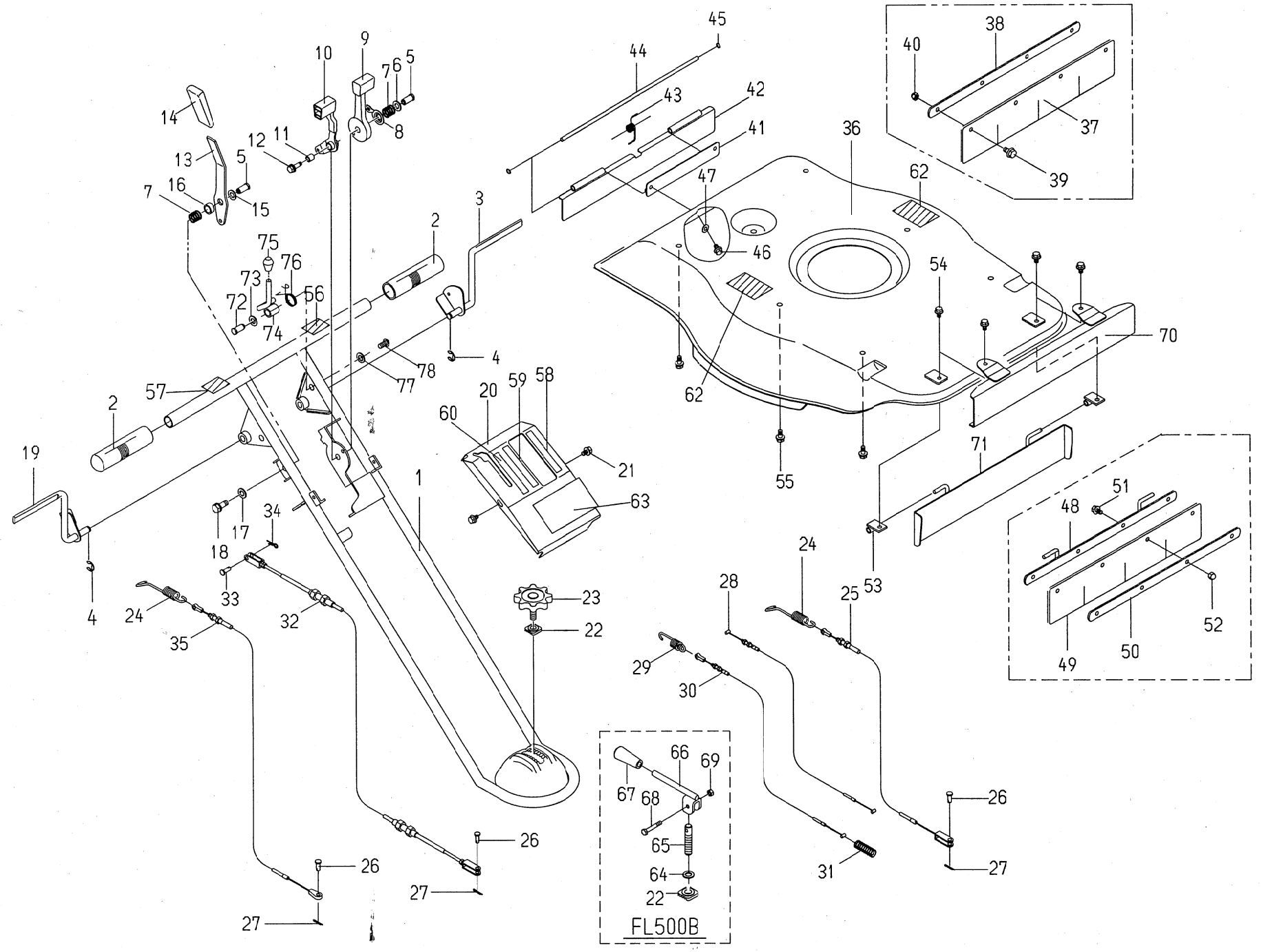

FIG.1 HANDLE & ROTARY COVER

Ref.	Parts No.	Parts Name	Quantity				(2Action)	Remarks
			FL 500A	FL 500A	FL 500B	FL 500BC	FL 500BC	
			FC150V	GXV160	GXV160	GXV160	GXV160	
1	80-1035-221-00	Handle	1	1	1	1		*19)
	0214-10100	Handle					1	*1) *20)
2	83-1035-416-00	GripCX-65						
	83-1035-411-00	Grip(21.7)	2	2	2	2	2	*1)
3	80-1035-251-00	Blade Lever	1	1				Remark 2
	80-1035-251-10	Blade Lever	1	1				*11) *12) Remark 2
	80-1035-251-20	Blade Lever (RED)	1	1	1	1		*13) *19)
	0214-10200	Blade Lever					1	*20)
4	89-2521-000082	E-Type Stopper 8	2	2	2	2	2	
5	80-1020-262-00	Control Lever Shaft	2	2	2	2	2	
6	89-1711-120002	Washer 12	1	1	1	1	1	
7	80-1020-263-00	Control Lever Shaft Spring	2	2	2	2	2	
8	80-1020-264-00	Control Washer	1	1	1	1	1	
9	80-1020-261-00	Throttle Lever (K)	1					
	80-1020-265-00	Throttle Lever (H)		1	1	1	1	
10	80-1020-260-00	Driving Change Lever	1	1				
	80-1022-260-00	Driving Change Lever	1	1	1	1	1	*1)
11	80-1020-270-00	Inner Collar	1	1	1	1	1	
12	89-1133-080302	Hexagonal Bolt (PWSW) M8*30	1	1				
	89-1232-080302	Mini Hexagonal Bolt (SW) M8*3	1	1	1	1	1	*1)
13	80-1035-260-10	Change Lever	1	1	1	1	1	
14	80-1515-262-00	Arm Grip	1	1	1	1	1	
15	83-1020-355-00	Thrust Washer 12*24*1.0	1	1	1	1	1	
16	80-1035-261-00	Collar 10A-L8	1	1	1	1	1	
17	89-1711-080002	Washer 8	1	1	1	1	1	
18	89-1132-080162	Hexagonal Bolt (SW) M8*16	1	1				
	89-1232-080162	Mini Hexagonal Bolt (SW) M8*1	1	1	1	1	1	*1)
19	80-1035-241-00	Driving Lever	1	1				Remark 3
	80-1035-241-10	Driving Lever	1	1				*11) *12) Remark 3
	80-1035-241-20	Driving Lever	1	1	1	1	1	*13)
20	80-1035-231-00	Control Cover	1	1	1	1	1	
21	89-1137-060152	Hexagonal Bolt (PW) M6*15	2	2	2	2	2	
22	80-1516-251-00	Handle Fix Washer	1	1				
	0013-10300	Handle Fix Washer			1	1	1	
23	80-1516-108-00	Knob Bolt M12*30	1	1				
24	80-1020-968-10	Blade Spring	2	2				*12)
	80-1035-941-00	Blade Spring	2	2	2	2	2	*13)
25	83-1035-945-00	Blade Wire	1	1	1	1	1	
26	89-2181-060162	Flat Headed Pin 6*16	3	3	3	3	3	
27	89-2120-200152	Pin 2*15	3	3	3	3	3	
28	83-1024-952-00	Throttle Wire V(K)	1					
	83-1022-955-10	Throttle Wire (H)		1	1	1	1	
29	80-1020-967-00	Drive Change Spring	1	1	1	1	1	
30	83-1035-937-00	Differential Lock Wire	1	1	1	1	1	
31	80-1035-162-00	Differential Lock Return Spring	1	1	1	1	1	
32	83-1035-936-00	Change Wire	1	1	1	1	1	
33	89-2181-060162	Flat Headed Pin 6*16	1	1	1	1	1	
34	89-2131-080002	Snap Pin 8	1	1	1	1	1	
35	83-1035-932-00	Driving Wire	1	1	1	1	1	

FIG.1 HANDLE & ROTARY COVER

Ref.	Parts No.	Parts Name	Quantity				(2Action)	Remarks
			FL 500A	FL 500A	FL 500B	FL 500BC	FL 500BC	
			FC150V	GXV160	GXV160	GXV160	GXV160	
36	80-1035-713-00	Rotery Cover						*4)
	80-1035-713-10	Rotery Cover	1	1	1			*5) *17)
	0214-60100	Rotery Cover				1	1	*1) *18)
37	80-1035-781-00	Rear Flapper						
38	80-1035-782-00	Rear Flapper Holder						*4)
39	89-1137-060152	Hexagonal Bolt (PW) M6*15						*4)
40	83-1575-189-00	Flange Cap Nut M6						*4)
41	80-1035-783-00	Rear Flapper Holder	1	1	1	1	1	*5)
42	80-1035-785-00	Rear Flapper	1	1	1	1	1	*5)
43	80-1035-784-00	Rear Flapper Holder Spring	1	1	1	1	1	*5)
44	83-1035-786-00	Rear Flapper Shaft	1	1	1	1	1	*5)
45	80-1035-986-00	Grip Stopper 5	2	2	2	2	2	*5)
46	89-1113-060162	Hexagonal Bolt (8T) M6*16	2	2	2	2	2	*5)
47	89-1750-060002	Spring Washer 6	2	2	2	2	2	*5)
48	80-1035-735-00	Front Flapper Setting	1	1	1			
49	83-1035-734-00	Front Flapper	1	1	1			
50	80-1035-736-00	Front Flapper Holder	1	1	1			
51	89-1137-060152	Hexagonal Bolt (PW) M6*15	4	4	4			
52	83-1575-189-00	Flange Cap Nut M6	4	4	4			
53	80-1035-737-00	Flapper Shaft Receiver	2	2	2	2	2	
54	89-1137-060152	Hexagonal Bolt (PW) M6*15	2	2	2	2	2	
55	89-1133-080162	Hexagonal Bolt (PWSW) M8*16	6	6				
	89-1233-080162	Mini Hexagonal Bolt (PWSW) M	6	6	6	6	6	*1)
56	80-1035-916-00	Knife Label	1	1	1	1		*19)
	0214-71400	Knife Label					1	*20)
57	80-1035-915-00	Driving Label	1	1	1	1		*19)
	0214-71500	Driving Label					1	*20)
58	80-1020-911-00	Throttle Label (K)	1					
	80-1020-913-00	Throttle Label (H)		1	1	1	1	
59	80-1417-906-00	Differential Lock Label	1	1	1	1	1	
60	80-1035-912-00	Change Label	1	1				
	80-1035-912-10	Change Label	1	1	1	1	1	*1)
62	80-1488-926-00	Attention Mark for Blade	2	2	2	2	2	
63	80-1035-906-00	Label Main (Small)	1	1	1	1	1	
64	89-1852-120000	Belleville Spring H12			1	1	1	
65	0018-70400	Handle Fixing Bolt			1	1	1	
66	0203-20400	Handle Fixing Lever			1			*17)
	0018-70500	Handle Fixing Lever				1	1	*18)
67	83-1210-425-00	Lever Grip 10			1	1	1	
68	89-1113-060302	Hexagonal Bolt (8T) M6*30			1	1	1	
69	89-1551-060002	Hexagonal U Nut M6			1	1	1	
70	0214-60300	Front Cover CMP				1	1	*18)
71	0214-60200	Front Flapper CMP				1	1	*18)
72	80-1020-262-00	Control Lever Shaft					1	*20)
73	89-1711-120002	Flat Washer 12					1	*20)
74	0214-10300	Rock Lever					1	*20)
75	83-1260-423-00	Grip Rubber					1	*20)
76	0214-70300	Spring for Rock Lever Return					1	*20)
77	89-1812-080002	Toothed washer (inside) 8					1	*20)
78	89-1159-080122	Truss Mini Screw M8*12					1	*20)

FIG.2 TRANSMISSION CASE

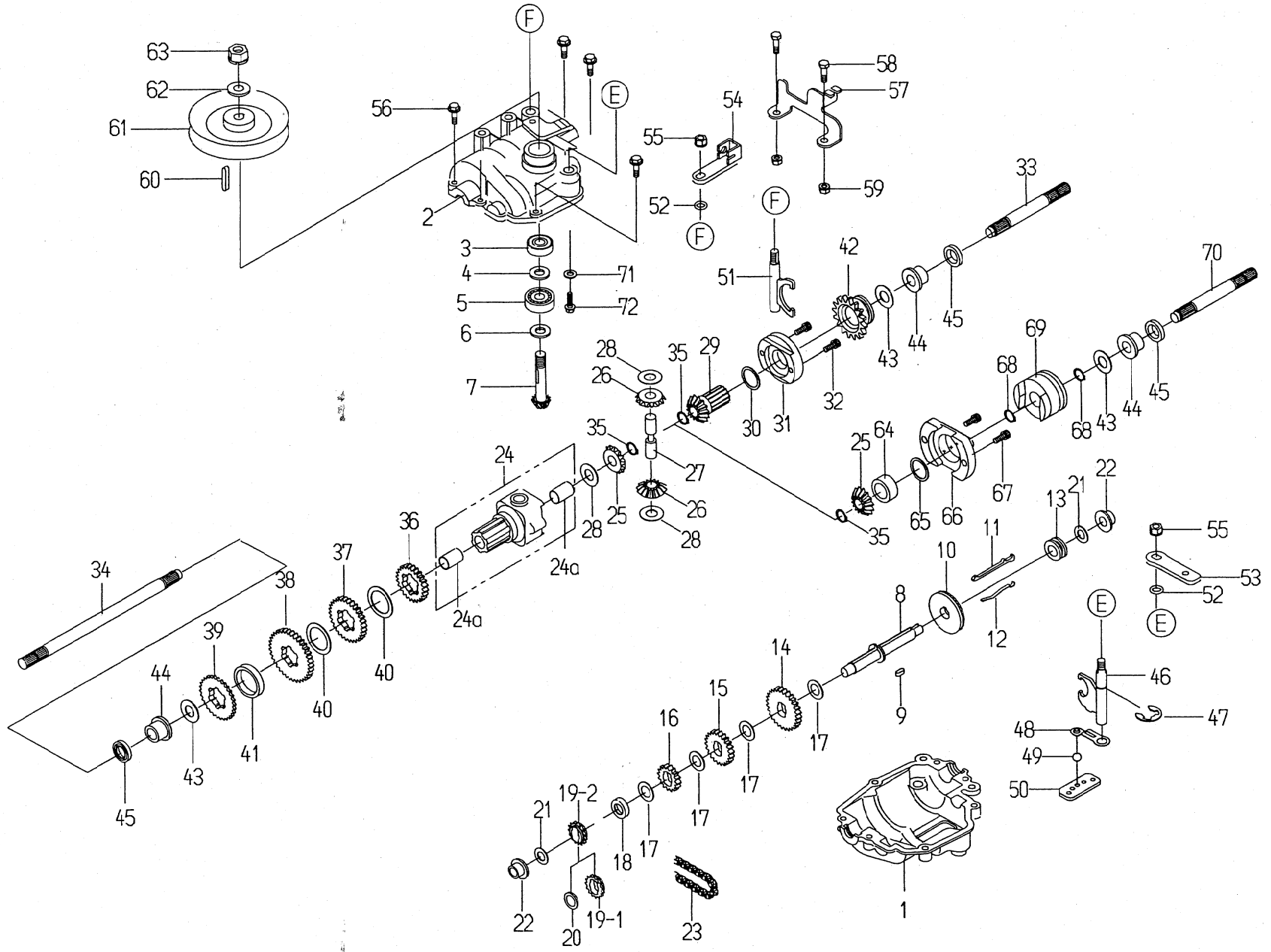

FIG.2 TRANSMISSION CASE

Ref.	Parts No.	Parts Name	Quantity				(2Action)	Remarks
			FL 500A	FL 500A	FL 500B	FL 500BC	FL 500BC	
			FC150V	GXV160	GXV160	GXV160	GXV160	
1~59	80-1035-100-00	Transmission Case ASSY						*7)
1~59	80-1035-100-10	Transmission Case ASSY	1	1	1	1	1	*1) *8)
1	80-1035-101-00	Transmission Case (Down)	1	1	1	1	1	
2	80-1035-103-00	Transmission Case (Upper)	1	1	1	1	1	
3	89-3115-060004	Bearing 6000 2RS	1	1	1	1	1	
4	89-1712-100000	Washer 10	1	1	1	1	1	
5	89-3111-062004	Bearing 6200	1	1	1	1	1	
6	83-1020-351-00	Thrust Washer 10*18*1.0	1	1	1	1	1	
7	80-1035-117-00	Pinion Bebel 13T	1	1	1	1	1	
8	80-1035-122-00	B Shaft	1	1	1	1	1	
9	89-2150-040100	Key 4*10	1	1	1	1	1	
10	80-1035-116-00	Bebel 35T	1	1	1	1	1	
11	80-1035-112-00	Shift Key	1	1	1	1	1	
12	80-1035-114-00	Shift Key Spring	1	1	1	1	1	
13	80-1035-111-00	Shift Collar	1	1	1	1	1	
14	80-1035-126-00	B Shaft Gear 28T	1	1	1	1	1	
15	80-1035-125-00	B Shaft Gear 22T	1	1	1	1	1	
16	80-1035-124-00	B Shaft Gear 16T	1	1	1	1	1	
17	80-1035-127-00	Thrust Washer 12*21*1.0	4	4	4	4	4	
18	80-1035-129-00	B Shaft N Collar	1	1	1	1	1	
19-1	80-1035-128-00	B Shaft Sprocket 15T						*7)
19-2	80-1035-128-10	B Shaft Sprocket 15T	1	1	1	1	1	*1) *8)
20	80-1035-123-00	Spacer 12*18*2						*7)
21	83-1020-351-00	Thrust Washer 10*18*1.0	2	2	2	2	2	
22	80-1035-171-00	Bush 10	2	2	2	2	2	
23	89-6512-015040	Chain #15H-40	1	1	1	1	1	
24	80-1035-151-00	Differential Case	1	1	1	1	1	
24a	89-3510-012150	DU Bush 12.15	2	2	2	2	2	
25	80-1035-154-00	Bevel Gear (Right Output) 14T						*7)
	80-1035-154-00	Bevel Gear (Right Output) 14T	2	2	2	2	2	*8)
26	80-1035-153-00	Differential Bevel Gear 14T	2	2	2	2	2	
27	80-1035-157-00	Differential Shaft	1	1	1	1	1	
28	83-1020-355-00	Thrust Washer 12*24*1.0	3	3	3	3	3	
29	80-1035-156-00	Bevel Gear (Left Output) 14T						*7)
30	83-1310-371-00	Thrust Washer 20*30*1.0						*7)
31	80-1035-152-00	Differential Case Cap						*7)
32	83-1035-142-00	Hexagonal Bolt M5*12						*7)
33	80-1035-146-00	Drive Shaft(L)						*7)
34	80-1035-147-00	Drive Shaft(R)	1	1	1	1	1	
35	89-2511-000100	Shaft Ring 10	2	2	2	2	2	
36	80-1035-133-00	Differential Case Gear 24T	1	1	1	1	1	
37	80-1035-132-00	Differential Case Gear 30T	1	1	1	1	1	
38	80-1035-131-00	Differential Case Gear 36T	1	1	1	1	1	
39	80-1035-138-00	Differential Case Sprocket 30T	1	1	1	1	1	
40	83-1783-376-00	Thrust Washer 25*34*1.0	2	2	2	2	2	
41	80-1035-139-00	Differential Case Collar	1	1	1	1	1	
42	80-1035-143-00	Driving Clutch						*7)
43	83-1020-355-00	Thrust Washer 12*24*1.0	2	2	2	2	2	
44	80-1035-172-00	Bush 12	2	2	2	2	2	
45	89-5130-122204	Oil Seal KE 12.22.4	2	2	2	2	2	
46	80-1035-108-00	Shift Folk	1	1	1	1	1	

FIG.2 TRANSMISSION CASE

Ref.	Parts No.	Parts Name	Quantity				(2Action)	Remarks
			FL 500A	FL 500A	FL 500B	FL 500BC	FL 500BC	
			FC150V	GXV160	GXV160	GXV160	GXV160	
47	89-2521-000080	E-Type Ring 8	1	1	1	1	1	
48	80-1035-160-00	Notch Ball Spring	1	1	1	1	1	
49	89-3410-050000	Ball 5	1	1	1	1	1	
50	80-1035-110-00	Notch Plate	1	1	1	1	1	
51	80-1035-113-00	Clutch Folk	1	1	1	1	1	
52	89-5221-010000	O Ring P10	2	2	2	2	2	
53	80-1035-193-00	Shift Arm	1	1	1	1	1	
54	80-1035-192-00	Differential Clutch Arm	1	1	1	1	1	
55	89-1541-080002	Hexagonal Nut (SW) M8	2	2	2	2	2	
56	83-1035-148-00	Tap Tight M6*18	7	7	7	7	7	
57	80-1035-191-00	Differential Lock Wire Setting	1	1	1	1	1	
58	89-1111-060252	Hexagonal Bolt M6*25	2	2	2	2	2	
59	89-1541-060002	Hexagonal Nut (SW) M6	2	2	2	2	2	
60	89-2150-030180	Key 3*18	1	1	1	1	1	
61	80-1035-521-00	Pulley	1	1				
	80-1035-586-00	Pulley(A)			1	1	1	
62	89-1712-100000	Washer 10	1	1	1	1	1	
63	89-1541-100002	Hexagonal Nut (SW) M10	1	1				
	89-1631-100002	Flange Mini Hexagonal Nut M10	1	1	1	1	1	*1)
64	80-1035-158-00	Differential Lock Collar	1	1	1	1	1	*8)
65	83-1830-368-00	Thrust Washer 18*26*1	1	1	1	1	1	*8)
66	80-1035-152-10	Differential Case Cap	1	1	1	1	1	*8)
67	83-1035-144-00	Hexagonal Bolt M5*16	2	2	2	2	2	*8)
68	89-2511-000120	Shaft Ring 12	2	2	2	2	2	*8)
69	80-1035-143-10	Differential Lock Men	1	1	1	1	1	*8)
70	80-1035-146-10	Drive Shaft(L)	1	1	1	1	1	*8)
71	89-1713-060002	Washer 6	1	1	1	1	1	
72	83-1020-148-00	Hexagonal Tap Tight M6*14	1	1	1	1	1	

M E M O

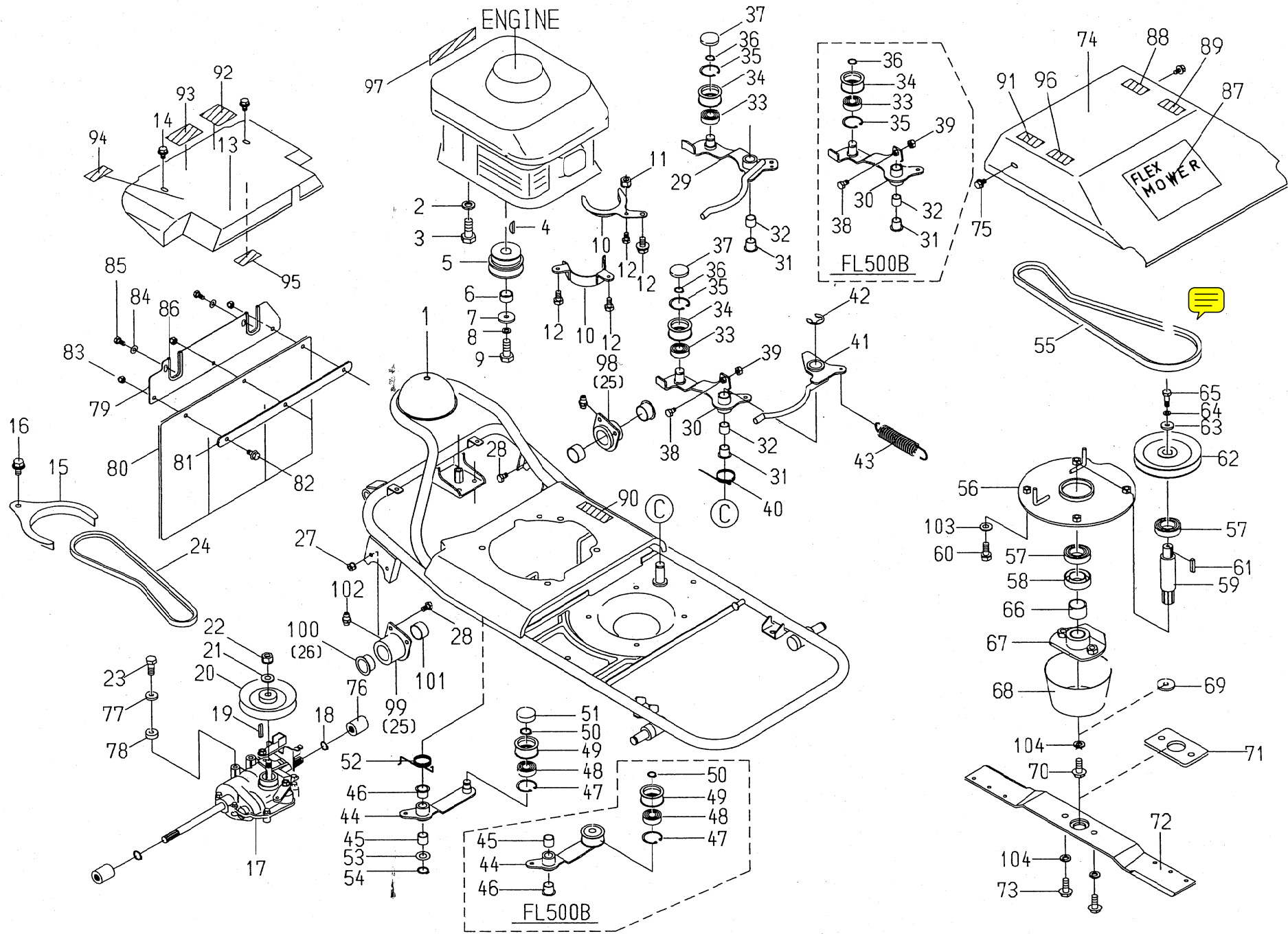

FIG.3 FRAME

FIG.3 FRAME

Ref.	Parts No.	Parts Name	Quantity				(2Action)	Remarks
			FL 500A	FL 500A	FL 500B	FL 500BC	FL 500BC	
			FC150V	GXV160	GXV160	GXV160	GXV160	
1	80-1035-301-00	Frame						
	80-1035-301-10	Frame	1	1				
	80-1035-301-20	Frame	1	1				
	80-1035-301-30	Frame			1	1		*19)
	0214-20100	Frame					1	*20)
2	89-1750-100002	Spring Washer 10	4					
	89-1750-080002	Spring Washer 8		4	4	4	4	
3	89-1113-100252	Hexagonal Bolt (8T) M10*25	4					
	83-1482-116-00	Hexagonal Bolt UNF5/16-24*25		4	4	4	4	
4	80-1020-892-00	Key 4*16	1	1	1	1	1	
5	80-1035-514-00	Engine Pulley (K)						
	80-1035-514-10	Engine Pulley (K)	1					
	80-1035-515-00	Engine Pulley (H)						
	80-1035-515-10	Engine Pulley (H)		1				
	80-1035-515-20	Engine Pulley (H)		1				
	80-1035-581-00	Engine Pulley AB (H)			1	1	1	
6	80-1035-512-00	Engine Pulley Collar 15						
	80-1035-513-00	Engine Pulley Collar 20						
	80-1035-516-00	Engine Pulley Collar 10	1	1				
7	83-1020-323-00	Washer 10*30*4.5	1	1	1	1	1	
8	89-1750-100002	Spring Washer 10	1	1	1	1	1	
9	83-1020-118-00	Hexagonal Bolt UNF3/8-24*32	1					
	89-1254-100252	Flange Bolt(Slender) M10*25		1	1	1	1	
10	80-1035-561-00	Engine Driving Belt Holder	1	1				
	80-1035-562-00	Engine Driving Belt Holder(HONDA)		1				*14) *15)
	80-1035-582-00	Engine Driving Belt Holder A(H)			1	1	1	*16)
11	89-1531-100042	Hexagonal Nut M10	1	1				
12	89-1133-080162	Hexagonal Bolt (PWSW) M8*16						
	83-1515-148-00	Tap Tight M6*22		1				
	89-1133-080302	Hexagonal Bolt (PWSW) M8*30	1					
	89-1233-080302	Mini Hexagonal Bolt (PWSW) M	1					
	83-1020-148-00	Hexagonal Tap Tight M6*14		1	2	2	2	
13	80-1035-755-00	Rear Cover	1	1	1	1		*19)
	0214-60400	Rear Cover CMP					1	*1) *20)
14	89-1131-060122	Hexagonal Bolt (PW) M6*12	1	1	2	2	2	
15	80-1035-527-00	Transmission Pulley Belt Holder	1	1				
	80-1035-583-00	Transmission Pulley Belt Holder A			1	1	1	
16	89-1133-080162	Hexagonal Bolt (PWSW) M8*16	1	1				
	89-1233-080162	Mini Hexagonal Bolt (PWSW) M	1	1	1	1	1	*1)
17	80-1035-100-00	Trasmission Case ASSY						
	80-1035-100-10	Trasmission Case ASSY	1	1	1	1	1	*1)
18	89-2511-000120	Snap Ring 12	2	2	2	2	2	
19	89-2150-030180	Key 3*18	1	1	1	1	1	
20	80-1035-521-00	Trasmission Pulley	1	1				
	80-1035-586-00	Trasmission Pulley A			1	1	1	
21	89-1711-100002	Washer 10	1	1	1	1	1	
22	89-1541-100002	Hexagonal Nut (SW) M10						
	89-1631-100002	Flange Mini Hexagonal Nut M10	1	1	1	1	1	*1)
23	83-1020-143-00	Tap Tight M8*18						
	83-1482-143-00	Tap Tight M8*25	1	1	1	1	1	

FIG.3 FRAME

Ref.	Parts No.	Parts Name	Quantity				(2Action)	Remarks
			FL 500A	FL 500A	FL 500B	FL 500BC	FL 500BC	
			FC150V	GXV160	GXV160	GXV160	GXV160	
24	89-6111-002500	V Belt M25	1	1				
	89-6111-002501	V Belt RM25	1	1				*1) *11)
	89-6122-002602	V Belt SA26(W400P)			1	1	1	*16)
25	80-1035-341-00	Rear Wheel Arm Receiver	2	2				*12)
26	89-3511-025300	DU Bush 25.30.36F	2	2				*12)
27	89-1541-060002	Hexagonal Nut (SW) M6	4	4	4	4	4	
28	89-1113-060162	Hexagonal Bolt (8T) M6*16	4	4	4	4	4	
29	80-1035-547-00	Blade Tension Arm						*2)
30	80-1035-547-10	Blade Tension Arm	1	1				*3)
	80-1035-585-00	Blade Tension Arm CMP			1	1	1	*16)
30~36	0214-41200	Blade Tension Arm Assy			1	1	1	
31	89-3511-015150	DU Bush 15.15.23F	1	1	1	1	1	
32	89-3510-015150	DU Bush 15.15	1	1	1	1	1	
33~35	83-1032-760-00	Tension Pulley Assy			1	1	1	
33	89-3115-062024	Bearing 6202 2RS	1	1				
	89-3115-062034	Bearing 6203 2RS			1	1	1	
34	83-1420-754-00	Tension Pulley	1	1				
	83-1032-765-00	Tension Pulley			1	1	1	
35	89-2512-000350	Snap Ring (R35)	1	1				
	89-2512-000400	Snap Ring (R40)			1	1	1	
36	89-2511-000150	Snap Ring (S15)	1	1				
	89-2511-000170	Snap Ring (S17)			1	1	1	
37	80-1035-985-00	Rubber Cap 35-4	1	1				
38	89-1113-060252	Hexagonal Bolt (8T) M6*25	1	1	1	1	1	
39	89-1511-060042	Hexagonal Nut M6	1	1	1	1	1	
40	80-1035-546-00	Spring 30	1	1	1	1	1	*3)
41	80-1035-548-00	Blade Brake	1	1	1	1		*3) *19)
	0214-40800	Blade Brake					1	*20)
42	89-2521-000122	E-Type Ring 12	1	1	1	1	1	
43	80-1035-373-00	Blade Brake Spring	1	1	1	1	1	
44~50	0214-41100	Driving Tension Arm Assy			1	1	1	
44	80-1035-543-00	Driving Tension Arm	1	1				
	80-1035-584-00	Driving Tension Arm			1	1	1	
45	89-3510-012100	DU Bush 12.10	1	1	1	1	1	
46	89-3511-012150	DU Bush 12.15.20F	1	1	1	1	1	
47	89-2512-000280	Snap Ring 28	1	1				
	89-2512-000350	Snap Ring (R35)			1	1	1	
48	89-3115-060014	Bearing 6001 2RS	1	1				
	89-3115-062024	Bearing 6202 2RS			1	1	1	
49	83-1035-765-10	Tension Pulley	1	1				
	83-1415-752-00	Tension Pulley			1	1	1	
50	89-2511-000120	Snap Ring 12	1	1				
	89-2511-000150	Snap Ring 15			1	1	1	
51	83-1035-679-00	Cap 25.7	1	1				
52	80-1035-552-00	Spring 26	1	1	1	1	1	
53	83-1020-355-00	Thrust Washer 12*24*1.0	1	1	1	1	1	
54	89-2511-000120	Snap Ring 12	1	1	1	1	1	
55	89-6122-003201	V Belt SA32	1	1				
	89-6122-003202	V Belt SA32(W400P)	1	1				*1) *11) *15)
	89-6123-003203	V Belt LB32(SG1000)			1	1	1	*16)

FIG.3 FRAME

Ref.	Parts No.	Parts Name	Quantity				(2Action)	Remarks
			FL 500A	FL 500A	FL 500B	FL 500BC	FL 500BC	
			FC150V	GXV160	GXV160	GXV160	GXV160	
56	80-1035-601-00	Blade Shaft Case	1	1				
	80-1035-601-10	Blade Shaft Case			1	1	1	
57	89-3115-062054	Bearing 6205 2RS	2	2	2	2	2	
58	83-1415-662-00	Oil Seal AP 35.55.8	1	1	1	1	1	
59	80-1035-641-00	Blade Shaft	1	1				
	80-1035-641-10	Blade Shaft	1	1	1	1	1	
60	89-1132-080202	Hexagonal Bolt (SW) M8*20	4	4				
	89-1232-080202	Mini Hexagonal Bolt (SW) M8*2	4	4	4	4	4	*1)
61	89-2151-050200	Key 5*20	1	1				
	89-2151-050250	Key 5*25			1	1	1	
62	80-1035-571-00	Knife Pulley	1	1				
	80-1035-587-00	Knife Pulley B			1	1	1	
63	83-1415-312-00	Washer 8*30*3.2	1	1	1	1	1	
64	89-1750-080002	Spring Washer 8	1	1	1	1	1	
65	89-1113-080202	Hexagonal Bolt (8T) M8*20	1	1				
	89-1253-080202	Flange Hexagonal Bolt (8T)	1	1	1	1	1	*1)
66	80-1035-813-00	Knife Shaft Collar	1	1	1	1	1	
67	80-1035-833-00	Knife Bracket	1	1				*12)
	80-1035-833-10	Knife Bracket			1	1	1	*1) *13) Remark 4
68	80-1035-836-00	Knife Neck Guard	1	1	1	1	1	
69	83-1035-323-00	Washer 10*30*3.2	1	1				*12)
70	89-1254-100252	Flange Bolt(Slender) M10*25	1	1	1	1	1	
71	80-1035-837-00	Knife Bracket Spacer	1	1				*12)
72	80-1035-821-00	Blade	1	1	1			*17)
	0214-70700	Blade				1	1	*1) *18)
73	89-1254-100252	Flange Bolt(Slender) M10*25	2	2	2	2	2	
74	80-1035-502-10	Front Bonnet	1	1	1	1	1	
75	89-1133-060152	Hexagonal Bolt (PWSW) M6*15	2	2	2	2	2	
76	80-1035-149-00	Drive Shaft Joint	2	2	2	2	2	
77	89-1711-080002	Washer 8	1	1	1	1	1	
78	80-1035-988-00	Spacer Rubber	1	1	1	1	1	
79	80-1035-751-00	Rear Guard	1	1	1	1	1	*5)
80	80-1035-752-00	Rear Guard Flapper	1	1	1	1	1	*5)
81	80-1035-753-00	Rear Guard Flapper Holder	1	1	1	1	1	*5)
82	89-1137-060152	Hexagonal Bolt (PW) M6*15	3	3	3	3	3	*5)
83	83-1575-189-00	Flange Cap Nut M6	3	3	3	3	3	*5)
84	89-1711-060002	Washer 6	2	2	2	2	2	*5)
85	89-1132-060162	Hexagonal Bolt (SW) M6*16	2	2	2	2	2	*5)
86	80-1751-591-00	Rubber	2	2	2	2	2	*5)
87	80-1035-905-00	Main Label (Large)	1	1	1	1	1	
88	83-1260-908-00	Attention Mark for Reversing	1	1	1	1	1	
89	83-1415-912-00	Attention Mark against	1	1	1	1	1	
90	Not for Sele	Name Plate	1	1	1	1	1	
91	83-1415-913-00	Label, Protection for Eyes	1	1	1	1	1	
92	80-1035-904-00	Label (FL500A)	1	1				
	0214-70300	Label (FL500B)			1			*17)
	0214-70800	Label (FL500BC)				1	1	*18)
93	80-1484-A47-00	Label, Caution (Large)	1	1	1	1	1	
94	80-1035-917-00	Label Cutting Height Adjusting	1	1	1	1	1	
95	80-1035-921-00	Label, Belt (Size)			1	1	1	
96	80-1488-928-00	Label, Caution for Belt Involving	1	1	1	1	1	

FIG.3 FRAME

Ref.	Parts No.	Parts Name	Quantity				(2Action)	Remarks
			FL 500A	FL 500A	FL 500B	FL 500BC	FL 500BC	
			FC150V	GXV160	GXV160	GXV160	GXV160	
97	83-1415-909-00	Sticker for Engine(Z18-6)	1	1	1	1	1	
98	80-1035-341-10	Rear Wheel Arm Receiver(L)			1	1	1	*13)
99	80-1035-342-00	Rear Wheel Arm Receiver(R)			1	1	1	*13)
100	89-3511-025100	DU Bush 25.10.36F			2	2	2	*13)
101	89-3510-025120	DU Bush 25.12			2	2	2	*13)
102	83-1415-975-00	Grease Nipple M6			2	2	2	*13)
103	83-1751-311-00	Washer 8*25*2.3	4	4	4	4	4	
104	89-1750-100002	Spring Washer 10	3	3	3	3	3	

M E M O

Remark 1 : Supplied Parts 80-1035-148-10(2 pcs)

Remark 2 : Supplied Parts 80-1035-251-20 . 80-1035-941-00 (1 set)

Remark 3 : Supplied Parts 80-1035-241-20 . 80-1035-941-00 (1 set)

Remark 4 : Disused 83-1035-323-00 . 80-1035-837-00

The Parts of Transmission Case ASSY(80-1035-100-10) are 1-18, 19(2), 21-28, 34-41. 43-59. 64-72.

*1)Interchangeable

*2)Serial Number : ~VQ96K00405

*3)Serial Number : XP96M00004~

*4)Serial Number : ~XP97A00209

*5)Serial Number : XP97B00001~

*6)Serial Number : XP97L00321~

*7)Serial Number : ~XP97M00420

*8)Serial Number : XP98B00001~

*9)Serial Number : ~XP98B00200

*10)Serial Number : XP98G00201~

*11)Serial Number : XP00A00001~

*12)Serial Number : ~XP00L00286

*13)Serial Number : XP00M00287~

*14)Serial Number : XP01K00186~

*15)Serial Number : ~XP01M00345

*16)Serial Number : XP01M00346~

*17)Serial Number : ~XP02C00021

*18)Serial Number : XP02J00022~

*19)Serial Number : ~XP03A00189

*20)Serial Number : XP03C00001~

FIG.4 WHEEL

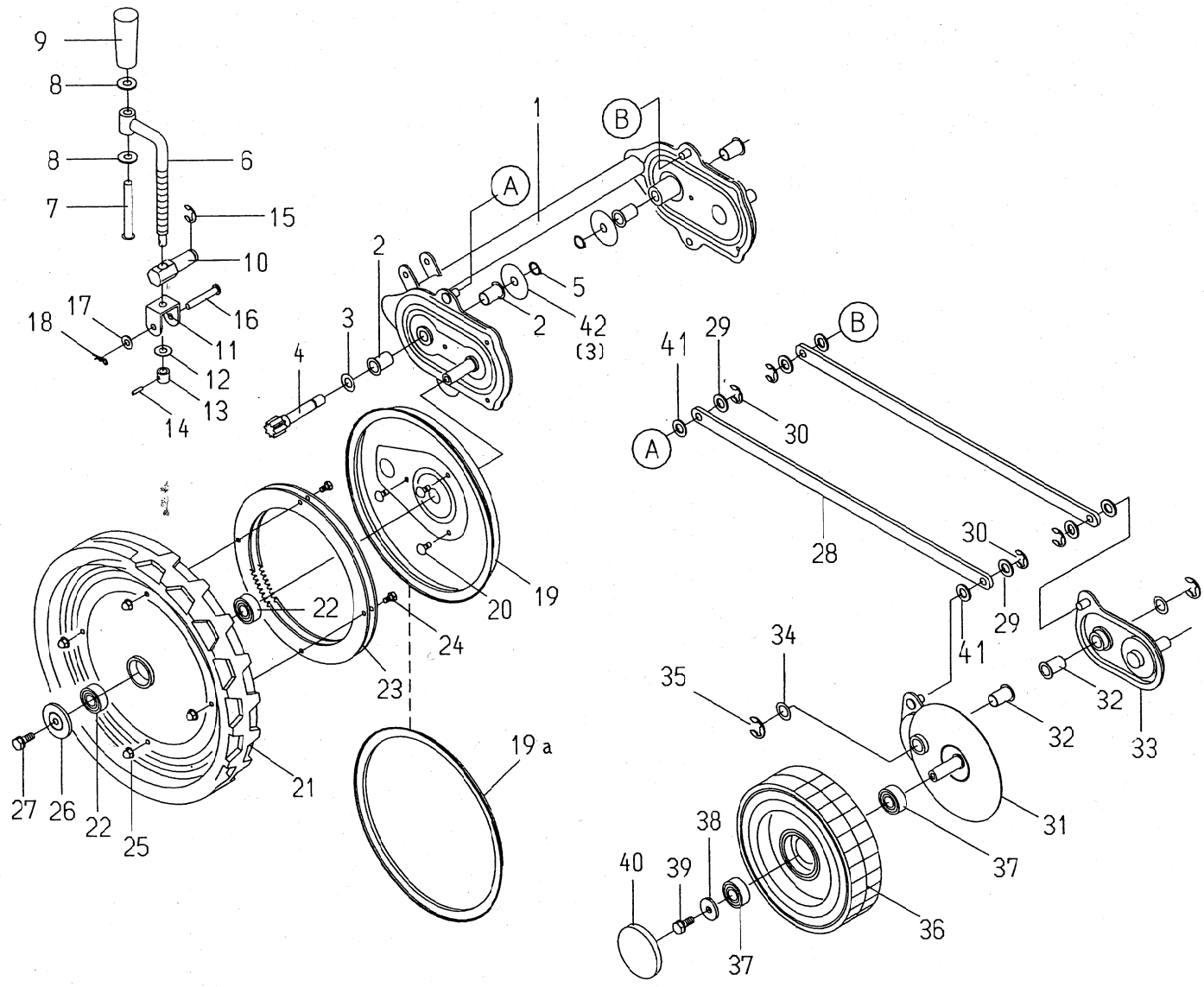

FIG.4 WHEEL

Ref.	Parts No.	Parts Name	Quantity				(2Action)	Remarks
			FL 500A	FL 500A	FL 500B	FL 500BC	FL 500BC	
			FC150V	GXV160	GXV160	GXV160	GXV160	
1	80-1035-415-10	Rear Wheel Arm	1	1	1	1	1	
2	89-3511-012150	DU Bush 12.15.20F	4	4	4	4	4	
3	83-1020-355-00	Thrust Washer 12*24*1.0	4	4				*12)
	83-1020-355-00	Thrust Washer 12*24*1.0	2	2	2	2	2	
4	80-1035-148-00	Drive Gear 8T						*9) Remark 1
	80-1035-148-10	Drive Gear 9T	2	2	2	2	2	*10)
5	89-2511-000120	Shaft Ring 12	2	2	2	2	2	
6	80-1035-743-00	Cutting Height Adjustment Scre	1	1	1			*17)
	0214-20200	Cutting Height Adjustment Screw				1	1	*18)
7	83-1713-166-00	Pin 10*80	1	1	1	1	1	
8	89-1711-100002	Washer 10	2	2	2	2	2	
9	83-1210-425-00	Lever Grip 10	1	1	1	1	1	
10	80-1035-742-00	Cutting Height Adjustment Sha	1	1	1	1	1	
11	80-1035-745-00	Screw Setting	1	1	1	1	1	
12	83-1020-351-00	Thrust Washer 10*18*1.0	1	1	1	1	1	
13	80-1035-744-00	Cutting Height Screw Stopper	1	1	1	1	1	
14	89-2111-040018	Spring Pin 4*18	1	1	1	1	1	
15	89-2521-000120	E-Type Ring 12	1	1	1	1	1	
16	83-1131-152-00	Flat Headed Pin 8*53	1	1	1	1	1	
17	89-1711-080002	Washer 8	1	1	1	1	1	
18	89-2131-080002	Snap Pin 8	1	1	1	1	1	
19	80-1035-418-00	Driving Gear Cover	2	2	2	2	2	
19a	80-1035-419-00	Rubber	2	2	2	2	2	
20	83-1035-149-00	Truss Tapping Screw M6*10	6	6	6	6	6	
21	80-1035-408-00	Tire 350*54	2	2	2	2	2	
22	89-3115-062024	Bearing 6202 2RS	4	4	4	4	4	
23	80-1035-421-00	Driven Gear 95T	4	4	4	4	4	
24	80-1035-971-00	Knok Bolt M6*16	8	8	8	8	8	
25	83-1575-189-00	Flange Cap Nut M6	8	8	8	8	8	
26	80-1035-411-00	Bearing Cover	2	2	2	2	2	
27	89-1132-080202	Hexagonal Bolt (SW) M8*20	2	2	2	2	2	
28	80-1035-416-00	Translation Bar	2	2	2	2	2	
29	89-1711-100002	Washer 10	8	8				
	89-1711-100002	Washer 10	4	4	4	4	4	*6)
30	89-2521-000080	E-Type Ring 8	4	4	4	4	4	
31	80-1035-405-00	Front Wheel Arm(R)	1	1	1	1	1	
32	89-3511-015250	DU Bush 15.25.23F	2	2	2	2	2	
33	80-1035-404-00	Front Wheel Arm(L)	1	1	1	1	1	
34	83-1020-361-00	Thrust Washer 15*24*1.0	2	2	2	2	2	
35	89-2521-000120	E-Type Ring 12	2	2	2	2	2	
36	80-1020-407-00	Front Wheel	2	2	2	2	2	
37	89-3115-062024	Bearing 6202 2RS	4	4	4	4	4	
38	83-1415-312-00	Washer 8*30*3.2	2	2	2	2	2	
39	89-1132-080202	Hexagonal Bolt (SW) M8*20	2	2	2	2	2	
40	80-1020-441-00	Wheel Cap	2	2	2	2	2	
41	80-1035-991-00	Rubber Washer 11*24*3	4	4	4	4	4	*6)
42	80-1035-907-00	Thrust Washer 12*30*1.0	2	2	2	2	2	*13)

M E M O