

Ersatzteilliste

Rasenmäher

MB 53 PRO (GR531C PRO)

MODEL	CODE NO.
GR531C PRO	0230-ΔΔΔΔΔ

CONTENTS

Fig.1	TRANSMISSION CASE-----	1
Fig.2	MISSION CASE INSIDE, OUTSIDE-----	3
Fig.3	COVER-----	5
Fig.4	WHEEL-----	9
Fig.5	HANDLE-----	11
Fig.6	BLADE, BAG-----	15

TELSNIG / OREC CO.,LTD.

Update : December 2002

Fig 1 Gear Case

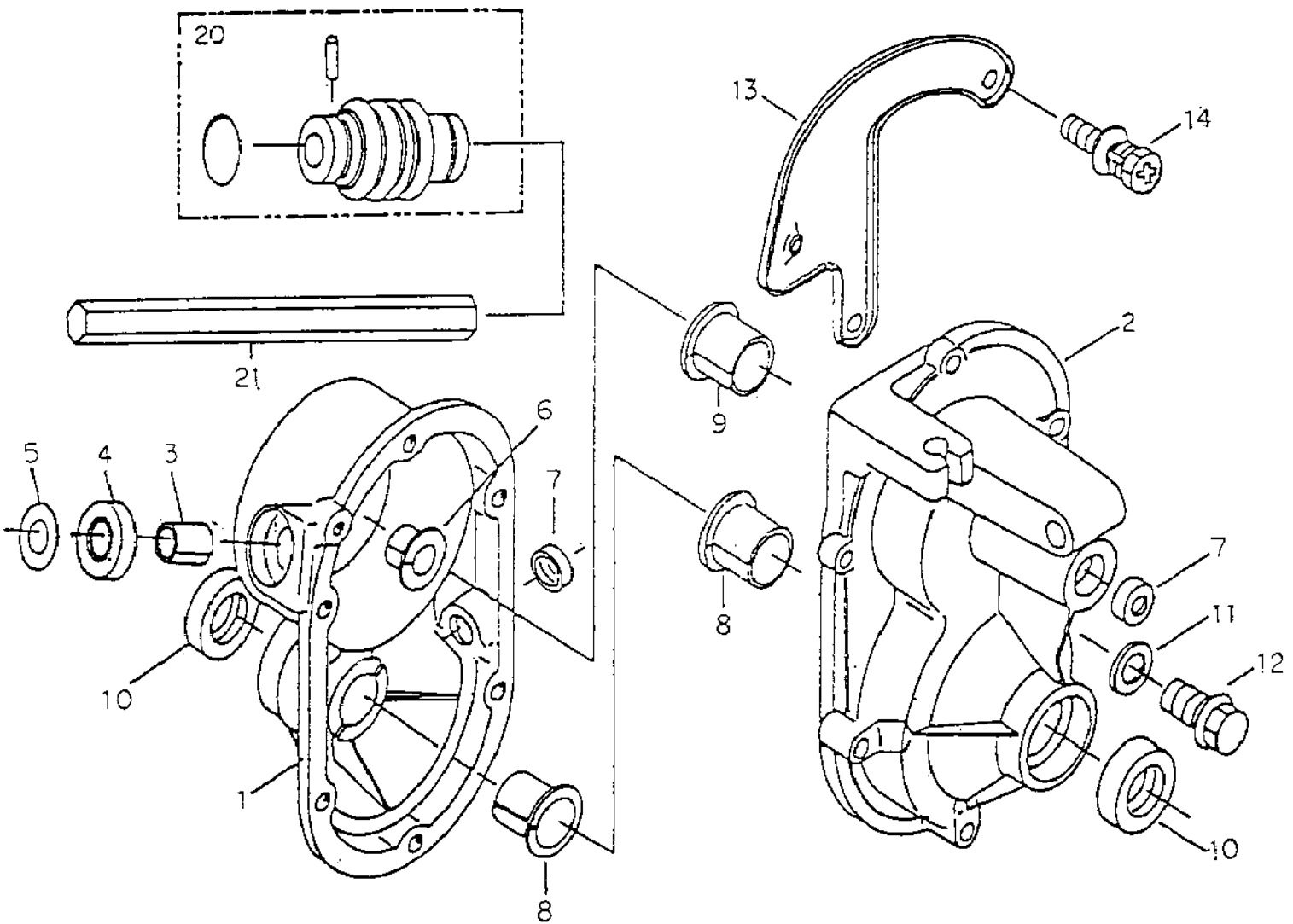

Fig 1 Gear Case

Pos.	ET-Nummer	Bezeichnung	Anzahl	Bemerkung
			MB 53 PRO	
			GXV160	
	80-1020-100-00	Gear Case Assy	1	Note 1
1	80-1020-101-00	Gear Case (Inside)	1	
2	80-1020-103-00	Gear Case (Outside)	1	
3	89-3512-010150	DBB Bush 10.15	1	
4	89-5121-102007	Oil Seal UE 10207	1	
5	83-1210-352-00	Thrust Washer 10*22*1.0	1	
6	89-3511-012100	DU Bush 12*10*20F	1	
7	89-5131-081404	Oil Seal KE8.14.4	2	
8	89-3511-015150	DU Bush 15*15*23F	2	
9	89-3511-016150	DU Bush 16*15*24F	1	
10	89-5121-152507	Oil Seal UE 15.25.7	2	
11	83-1020-349-00	Packing 10.5*18*1.6	1	
12	89-1254-100143	Flange Mini Bolt M10*1.25*14	1	
13	80-1020-198-10	Lock Arm Bracket B	1	
14	89-1144-060223	Hexagonal Bolt(PWSW) M6*22	6	
20	80-1020-515-00	Universal Joint NC-10-37C1	2	
21	80-1020-526-00	Drive Shaft H 136L	1	

MEMO

Note 1: Transmission ASSY consists from parts 1 to 20(this page)
and 1 to 24(next page).

Fig 2 Gear Case (Inside, Outside)

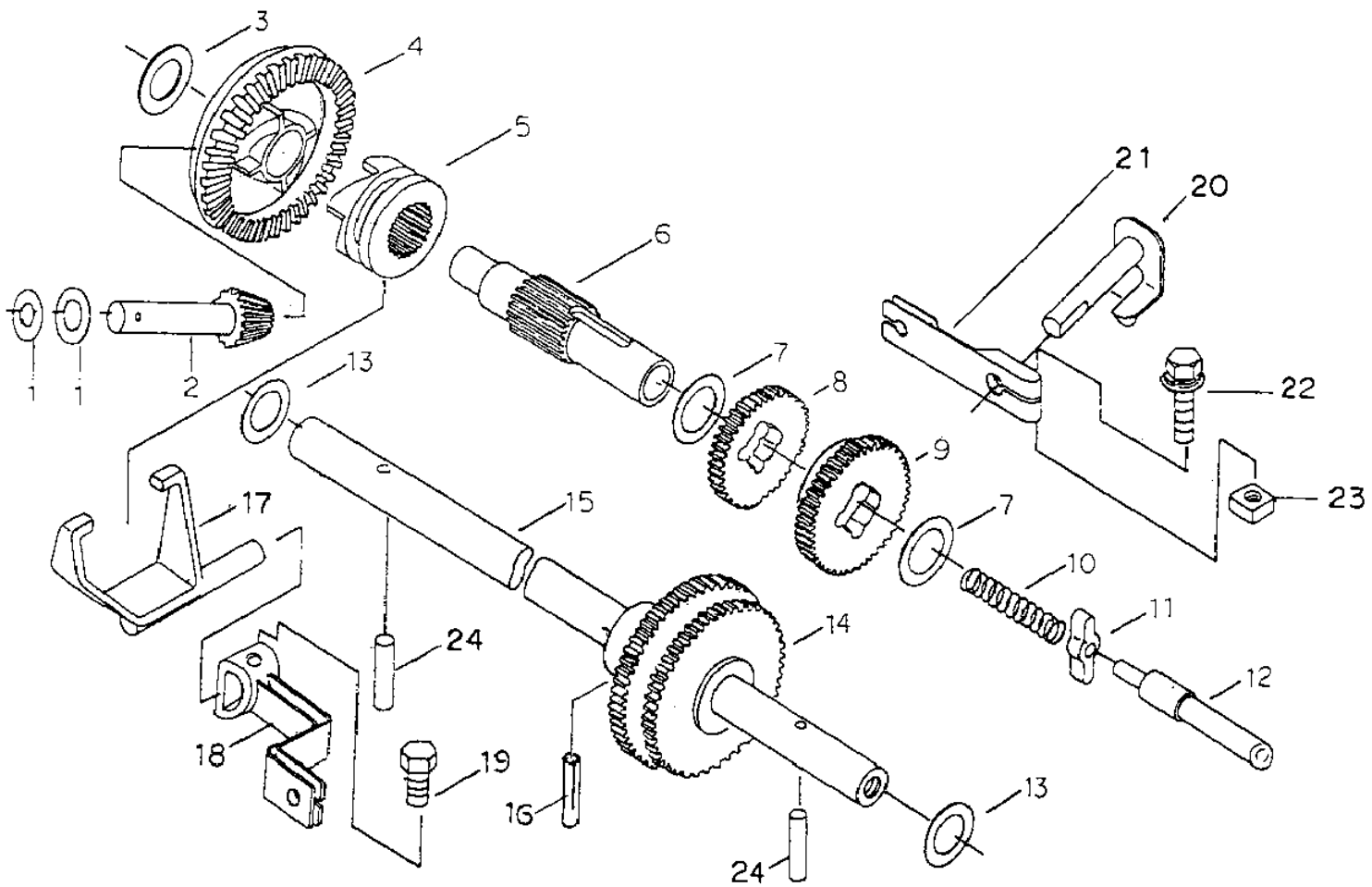

Fig 2 Gear Case (Inside, Outside)

Pos.	ET-Nummer	Bezeichnung	Anzahl	Bemerkung
			MB 53 PRO	
			GXV160	
1	83-1020-351-00	Thrust Washer 10	2	
2,4	80-1020-115-10	Pinion Bevel&Bevel Gear Assy	1	
2	80-1020-116-10	Pinion Bevel	1	
3	83-1020-355-00	Thrust Washer 12	1	
4	80-1020-117-10	Bevel Gear 53-tooth	1	
5	80-1020-119-10	Clutch for Driving	1	
6	80-1020-118-20	Main Shaft	1	
7	83-1020-363-00	Thrust Washer 16	2	
8,9	80-1020-125-10	Gear Assy (Low and High)	1	
8	80-1020-123-10	Gear (Low)	1	
9	80-1020-121-10	Gear (High)	1	
10	80-1020-161-00	Shaft Spring	1	
11	80-1020-108-00	Change Guide	1	
12	80-1020-107-00	Change Rod	1	
13	83-1020-361-00	Thrust Washer 15	2	
14	80-1020-148-30	Axle Gear	1	
15	80-1020-146-00	Axle	1	
16	83-1020-157-00	Spring Pin 5*25	1	
17	80-1020-113-00	Clutch Fork	1	
18	80-1020-153-10	Clutch Arm	1	
19	89-1113-060123	Bolt 8T M6x12	1	
20	80-1020-106-00	Shaft Arm	1	
21	80-1020-193-10	Change Arm	1	
22	89-1144-060253	Bolt & PW SW Assy M6*25	1	
23	83-1020-198-00	Square Nut M6	1	
24	89-2142-050250	Pin 5*25	2	

MEMO

Fig 3 Safety Cover

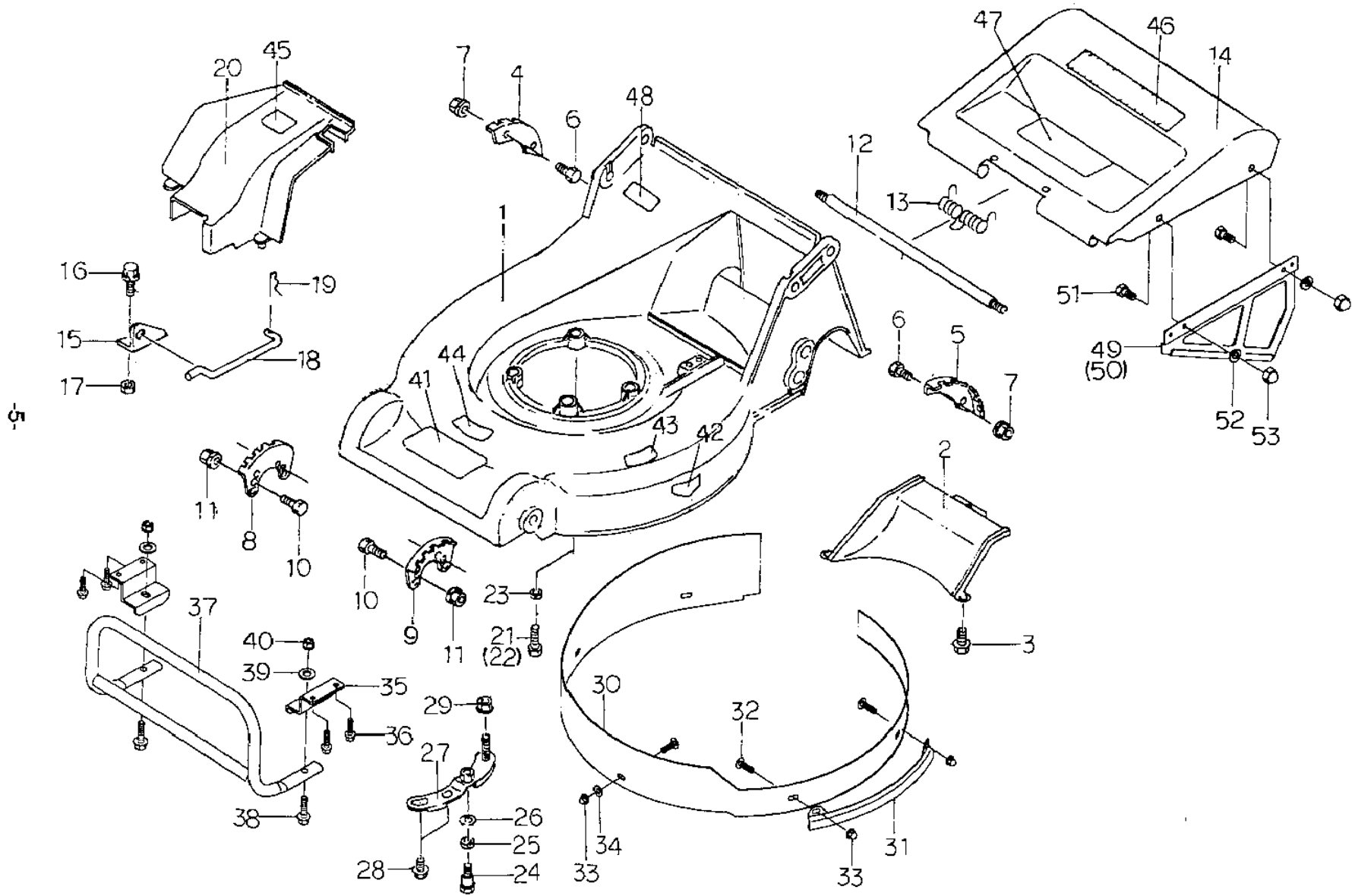

Fig 3 Safety Cover

Pos.	ET-Nummer	Bezeichnung	Anzahl	Bemerkung
			MB 53 PRO GXV160	
1	0230-20100	Cover Pro (Body) 531	1	
2	80-1022-714-00	Guide 531	1	
3	83-1020-148-00	Tapping Bolt M6*14	3	
4	0230-20500	Rear Wheel Adjusting Plate(R)	1	
5	0230-20400	Rear Wheel Adjusting Plate(L)	1	
6	89-1113-060143	Hexagonal Bolt(8T) M6*14	4	
7	89-1541-060003	Hexagonal Nut(SW) M6	4	
8	0230-20300	Front Wheel Adjusting Plate(R)	1	
9	0230-20200	Front Wheel Adjusting Plate(L)	1	
10	89-1113-060143	Hexagonal Bolt(8T) M6*14	4	
11	89-1541-060003	Hexagonal Nut(SW) M6	4	
12	80-1020-207-10	Rear Cover Shaft	1	
13	80-1020-753-00	Rear Cover Spring	1	
14	80-1022-751-00	Rear Cover	1	
15	80-1020-705-30	Lock Arm Bracket A	1	
16	89-1132-080253	Bolt & SW Assy M8*25	2	
17	89-1511-080043	Nut M8	2	
18	80-1020-707-20	Lock Arm	1	
19	89-2131-080002	Snap Pin 8	1	
20	80-1022-733-00	Gear Case Cover(H)	1	
21	83-1020-116-00	Bolt 5/16-24*45UNF (H)	2	
22	83-1022-116-00	Bolt 5/16-24*35UNF (H)	1	
23	89-1750-080003	Spring Washer 8 (H)	2	
24	80-1010-789-00	Engine Setting Bolt (H)	1	
25	89-1750-100003	Spring Washer 10(H)	1	
26	89-1711-100003	Washer 10(H)	1	
27	80-1020-721-00	HONDA Engine Stay (H)	1	
28	83-1020-148-00	Tapping Bolt M6*14(H)	2	
29	83-1310-191-00	Nut M8(H)	1	
30	0230-20600	Inside Guard CMP	1	
31	0230-20700	Side Guard	2	
32	89-1390-060142	Welded Bolt M6*14	5	
33	83-1575-189-00	Flange Cap Nut M6	5	
34	89-1711-060002	Flat Washer 6	1	
35	0230-20900	Front Bumper Setting Plate	2	
36	83-1020-148-00	Tapping Bolt M6*14	4	
37	0230-20800	Front Bumper CMP	1	
38	89-1213-080252	Mini Hexagonal Bolt (8T) M8*25	2	
39	89-1712-080002	Washer 8	2	
40	89-1543-080002	Mini Hexagonal Nut (SW) M8	2	
41	80-1020-902-00	Label (Large)	1	
42	80-1020-926-00	Danger Label	2	
43	80-1020-907-00	Step Label	1	
44	80-1020-928-00	Notice Label (Plug)	1	
45	80-1022-909-00	Notice Label (Cover)	1	
46	80-1020-929-00	Notice Label (Cover)	1	
47	80-1484-A47-00	Label, Caution	1	
48	80-1488-926-00	Attention Mark for Blade (13062)	1	

Fig 3 Safety Cover

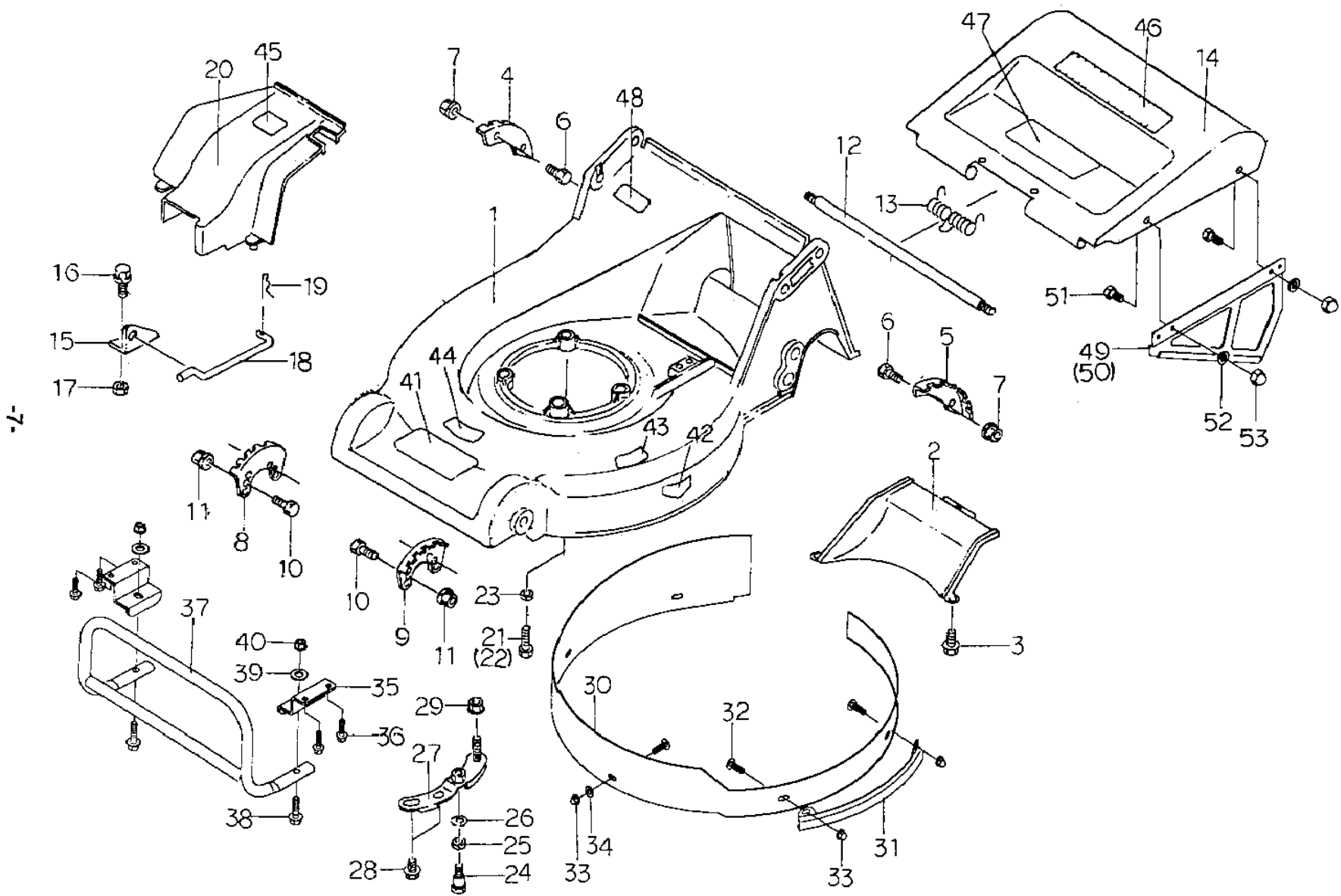

Fig 3 Safety Cover

Pos.	ET-Nummer	Bezeichnung	Anzahl	Bemerkung
			MB 53 PRO	
			GXV160	
49	80-1020-755-20	Side Plate(Left)	1	
50	80-1020-754-20	Side Plate(Right)	1	
51	89-1111-060102	Hexagonal Bolt M6*10	4	
52	89-1750-060003	Spring Washer 6	4	
53	89-1571-060043	Cap Nut M6	4	

Fig 4 Wheel

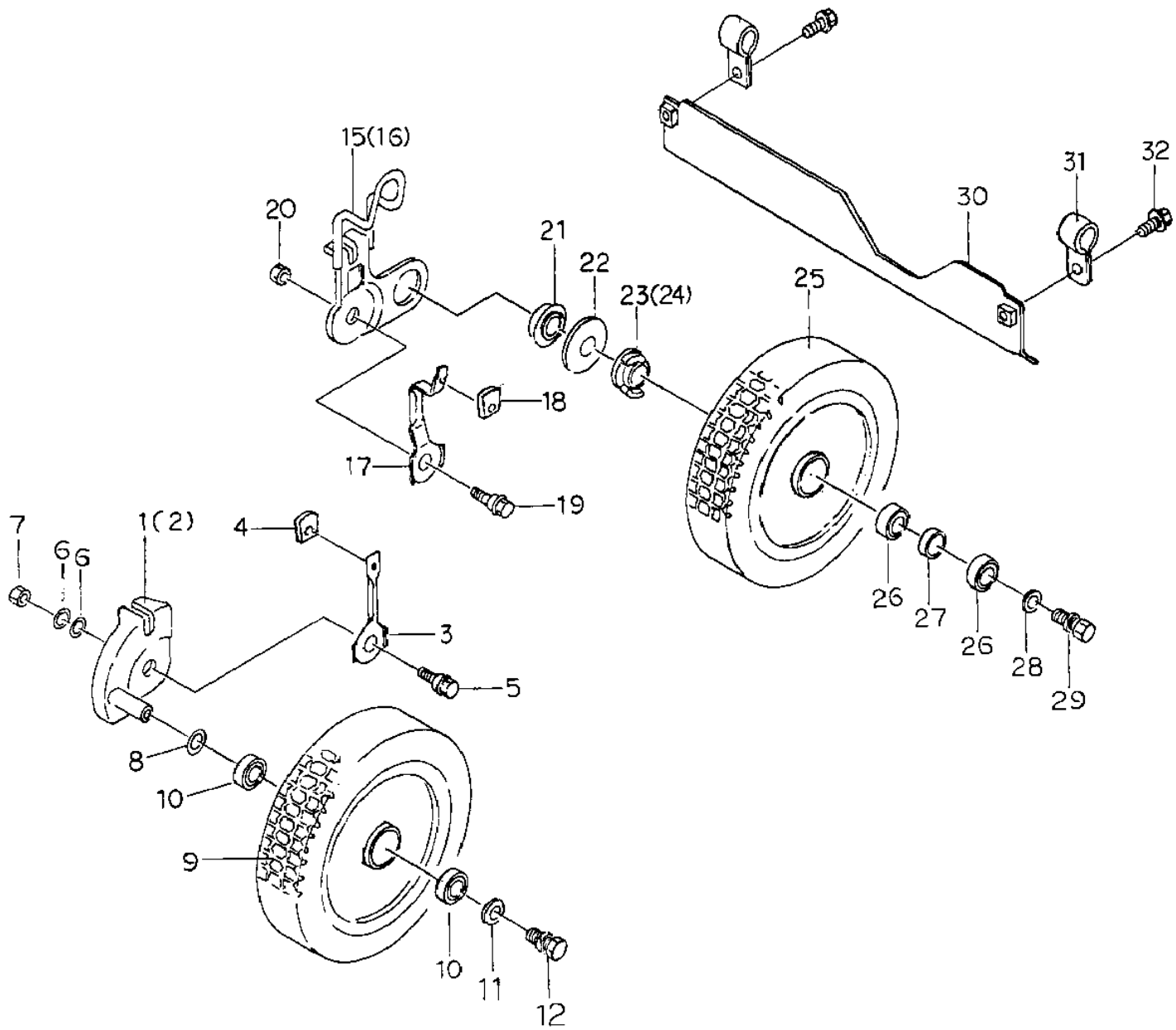

Fig 4 Wheel

Pos.	ET-Nummer	Bezeichnung	Anzahl	Bemerkung
			MB 53 PRO GXV160	
1	80-1020-404-10	Front Wheel Arm (L)	1	
2	80-1020-405-10	Front Wheel Arm (R)	1	
3	80-1022-424-00	Front Wheel Arm Stopper	2	
4	80-1020-426-10	Adjuster Grip	2	
5	80-1020-406-10	Arm Bolt	2	
6	83-1020-395-00	Washer 8*12 t0.8	2	For Adjustment
7	89-1551-080003	U-Nut M8	2	
8	83-1020-361-00	Thrust Washer 15	2	
9~10	80-1020-481-00	Steel Front Wheel Assy	2	
9	80-1020-483-00	Steel Front Wheel	2	
10	89-3115-062024	Bearing 6202 2RS	4	
11	89-1713-080003	Washer 8	2	
12	89-1132-080203	Hexagonal Bolt (SW) M8*20	2	
15	80-1022-414-00	Rear Wheel Arm (Left)	1	
16	80-1022-415-00	Rear Wheel Arm (Right)	1	
17	80-1022-425-00	Rear Wheel Arm Stopper	2	
18	80-1020-426-10	Grip	2	
19	80-1020-406-10	Arm Bolt	2	
20	89-1551-080003	U-Nut M8	2	
21	83-1020-987-00	Bearing ND-0.2	2	
22	80-1020-433-00	Coned Disc Spring	2	
23	80-1020-458-00	Ratchet Assembly (Left)	1	
24	80-1020-459-00	Ratchet Assembly (Right)	1	
25~27	80-1020-482-00	Steel Rear Wheel Assy	2	
25	80-1020-484-00	Steel Rear Wheel	2	
26	89-3115-062024	Bearing 6202 2RS	4	
27	80-1020-486-00	Collar 25A*8L	2	
28	89-1713-080003	Washer 8	2	
29	89-1132-080203	Hexagonal Bolt (SW) M8*20	2	
30	80-1020-792-00	Flapper	1	
31	80-1020-793-10	Flapper Setting	2	
32	89-1133-060163	Bolt & PW SW Assy M6*16	2	

2-Action

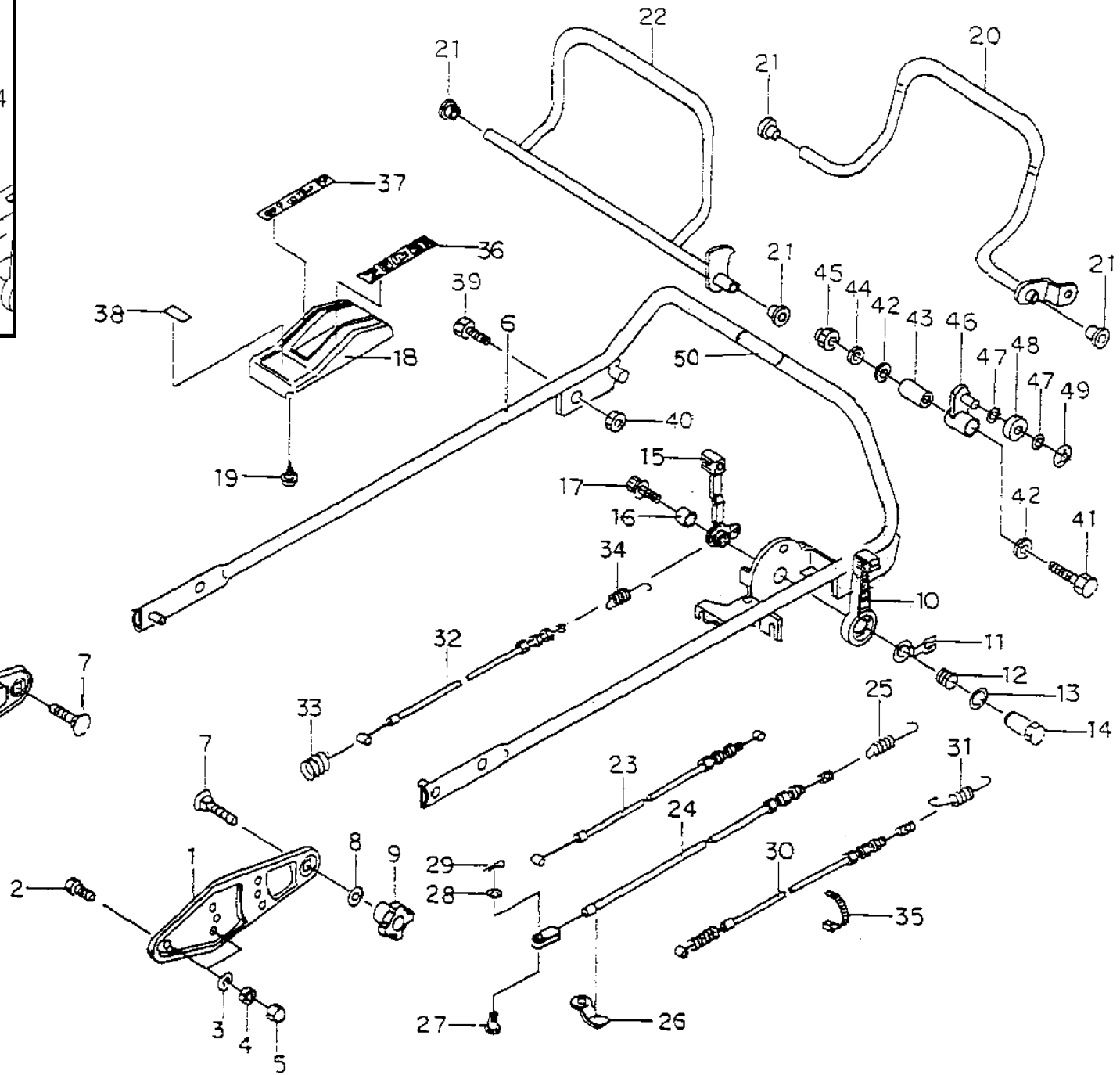
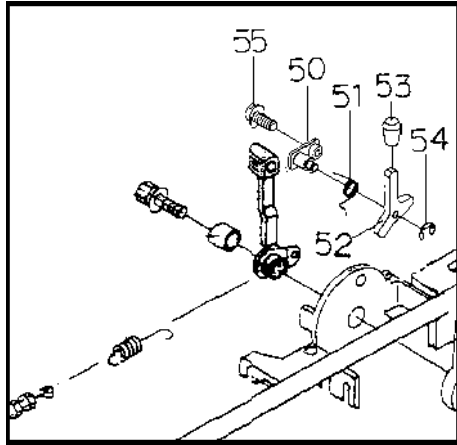

Fig 5 Handle

Fig 5 Handle

Pos.	ET-Nummer	Bezeichnung	Anzahl	Bemerkung
			MB 53	
			PRO GXV160	
1	80-1022-201-00	Handle Setting	2	
2	89-1113-080253	Bolt 8T M8*25	2	
3	89-1711-080003	Washer 8	4	
4	89-1750-080003	Spring Washer 8	4	
5	89-1571-080043	Cap Nut M8	4	
6	0230-10100	Handle D PRO	1	
7	89-1412-080403	Bolt M8*40	2	
8	89-1711-080003	Washer 8	2	
9	80-1020-228-10	Knob Nut M8	2	
10	80-1020-265-00	Throttle Lever (H)	1	
11	80-1020-264-00	Washer	1	
12	80-1020-263-00	Lever Shaft Spring	1	
13	89-1711-120003	Washer 13*21	1	
14	80-1020-262-00	Lever Shaft	1	
15	80-1022-260-00	Change Lever	1	
16	80-1020-270-00	Inner Collar	1	
17	89-1133-080303	Bolt & PW SW Assy M8*30	1	
18	80-1020-231-00	Control Case	1	
19	89-1161-050123	Tapping Screw 5*12	2	
20	80-1022-242-00	Driving Lever	1	
21	80-1020-243-00	Driving Lever, Metal	4	
22	80-1022-252-00	Blade Lever	2	
23	83-1022-955-10	Throttle Wire (H)	1	
24	83-1024-945-00	Blade Wire V	1	
25	80-1021-968-10	Blade Spring VB	1	
26	80-1010-717-00	Blade Wire Setting	1	
27	89-2181-060162	Pin 6*16	1	
28	89-1711-060002	Washer 6	1	
29	89-2120-200152	Split Pin 2*15	1	
30	83-1024-932-00	Driving Wire V	1	
31	80-1022-966-10	Driving Clutch Spring	1	
32	83-1024-936-00	Driving Change Wire V	1	
33	80-1020-969-00	Change Return Spring	1	
34	80-1020-967-00	Change Spring	1	
35	83-1415-718-00	Wire Band	2	
36	80-1020-913-00	Throttle Label (H)	1	
37	80-1020-912-00	Change Label	1	
38	80-1020-903-00	Label (Small)		
39	89-1113-080303	Hexagonal Bolt (8T) M8*30	1	
40	89-1511-080043	Hexagonal Nut M8	1	
41	80-1113-080503	Hexagonal Bolt (8T) M8*50	1	
42	89-1713-080003	Washer 8	2	
43	80-1022-254-00	Inner Pipe 13.8*30	1	
44	89-1750-080003	Spring Washer 8	1	

Fig 5 Handle

Pos.	ET-Nummer	Bezeichnung	Anzahl	Bemerkung
			MB 53 PRO GXV160	
45	89-1571-080043	Cap Nut M8	1	
46	80-1021-252-00	Blade Wire Arm	1	
47	83-1020-395-00	Shim Washer 8x12x*.8	2	
48	80-1021-253-00	Roller	1	With Bush 08.07
49	83-1021-195-00	Push Nut 8	1	
50	80-1023-A09-00	Driving Label	1	

MEMO

2-Action

50	0230-10500	Rock Lever Shaft CMP				1
51	0230-70700	Spring for Rock Lever Return				1
52	0230-10400	Rock Lever				1
53	83-1920-425-00	Lever Grip KP204				1
54	89-2521-000050	E Type Ring 5				1
55	89-1139-060163	Hexagonal Bolt (PWSW) M6*16				1
56	0230-71200	Blade Label				1
57	0230-71300	Driving Label				1
58	80-1023-A09-00	Driving & Blade Label				1

Fig 6 Blade and Bag

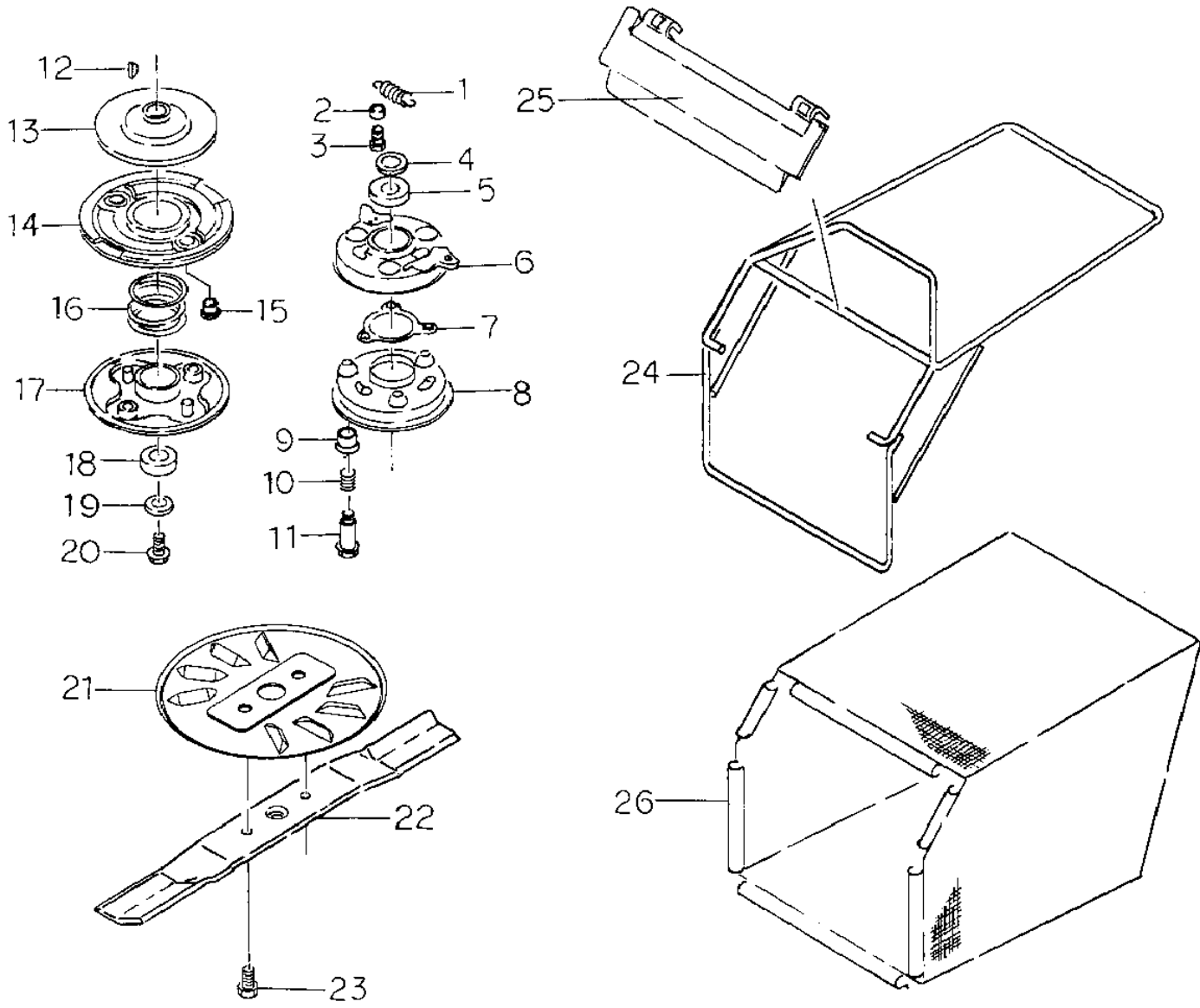

Fig 6 Blade and Bag

Pos.	ET-Nummer	Bezeichnung	Anzahl	Bemerkung
			MB 53 PRO GXV160	
1	80-1020-871-00	Clutch Return Spring (H)	2	
2	80-1020-872-00	Collar (H)	2	
3	83-1020-148-00	Tapping Bolt M6*14(H)	2	
4	80-1020-874-00	Thrust Washer (H)	1	
5	80-1020-875-00	Ball Bearing (H)	1	
6	80-1020-876-00	Blade (H) Assy	1	
7	80-1020-877-00	Ball Retainer (H)	1	
8	80-1020-878-00	Blade Disc (H) Assy	1	
9	80-1020-879-00	Bush (H)	3	
10	80-1020-881-00	Spring (H)	3	
11	80-1020-882-00	Blade Setting Bolt (H)	3	
12	80-1020-892-00	Woodruff Key 4*16	1	
13	80-1020-883-00	Drive Disc (H)	1	
14	80-1020-884-00	Driven Disc (H) Assy	1	
15	80-1020-885-00	Bush (H)	2	
16	80-1020-886-00	Clutch Spring (H)	1	
17	80-1020-887-00	Ball Control Plate (H) Assy	1	
18	80-1020-888-00	Ball Bearing (H)	1	
19	83-1020-323-00	Washer 10*30t4.5 (H)	1	
20	89-1254-100252	Flange Bolt M10*1.25*25 (H)	1	
21	0222-50100	BBC Cover CMP	1	
22	80-1020-821-10	Blade 530	1	
23	89-1254-100252	Flange Bolt M10*1.25*25 (H)	2	
24	80-1022-851-00	Bag Flame	1	
25	80-1022-854-00	Bag Plate	1	
26	0230-70400	Bag C	1	